

# ECLIPSE AIR HEAT BURNERS

## Dimensions—Series "TAH-R"

Data 142-2

11/93

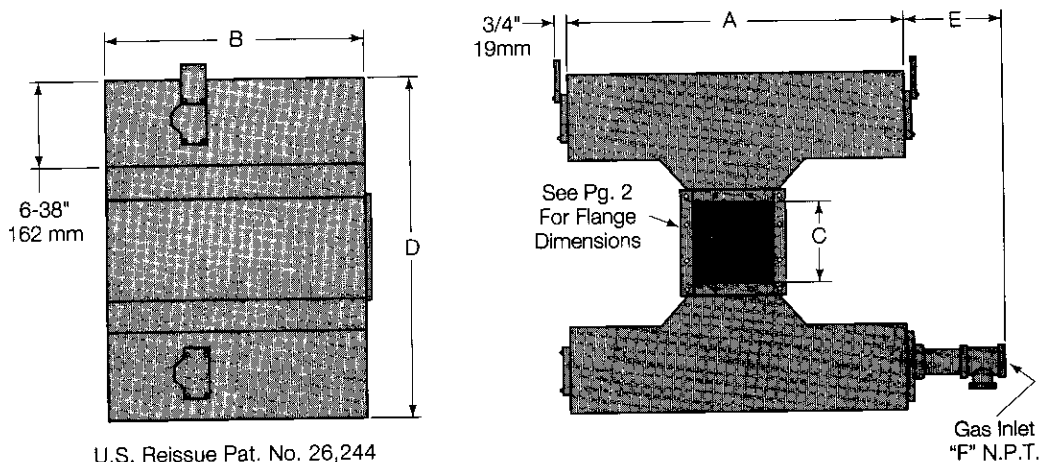

U.S. Reissue Pat. No. 26,244  
Canadian Pat. No. 743,782

### English Units

Burner Cat. No.	Assy. No.	Total Input MM Btu/Hr.		Typical Blower Cat. No.†	Dimensions In Inches						Cross Sect. Area Sq. In.	Check Valve Pipe Style*	Approx. Ship Wt. Lbs.
		0.8MM Btu/Ft.	1.0MM Btu/Ft.		A	B	C	D	E	F			
240 TAH-R	109449	2.4	3.0	65-84S-1/3	12-1/8	12-5/16	6	18-7/8	9-1/2	2	230	A	121
280 TAH-R	109450	2.8	3.5	65-84S-1/2	12-1/8	12-5/16	12	24-7/8	9-7/8	2	269	C	138
320 TAH-R	109451	3.2	4.0	66-94S-3/4	12-1/8	12-5/16	12	30-7/8	9-7/8	2	307	C	159
360 TAH-R	109452	3.6	4.5	66-94S-3/4	12-1/8	18-13/16	12	36-7/8	9-7/8	2	345	C	179
400 TAH-R	109453	4.0	5.0	66-94S-3/4	24-1/8	18-13/16	12	18-7/8	9-7/8	2	383	D	201
440 TAH-R	109454	4.4	5.5	66-94S-3/4	24-1/8	18-13/16	12	24-7/8	10-1/2	3	422	C	219
480 TAH-R	109455	4.8	6.0	67-115S-1-1/2	24-1/8	18-13/16	12	30-7/8	10-1/2	3	460	C	243
520 TAH-R	109456	5.2	6.5	67-115S-1-1/2	24-1/8	18-13/16	18	36-7/8	10-1/2	3	498	C	274
560 TAH-R	109457	5.6	7.0	67-115S-2	36-1/8	18-13/16	18	18-7/8	10-1/2	3	536	D	306
600 TAH-R	109458	6.0	7.5	67-115S-2	36-1/8	18-13/16	18	24-7/8	10-1/2	3	575	C	339
640 TAH-R	109459	6.4	8.0	67-115S-2	36-1/8	18-13/16	18	30-7/8	10-1/2	3	613	C	354
680 TAH-R	109460	6.8	8.5	78-126S-3	36-1/8	18-13/16	18	36-7/8	10-1/2	3	651	C	380
720 TAH-R	109461	7.2	9.0	78-126S-3	36-1/8	18-13/16	18	42-7/8	10-1/2	3	689	C	405

### Metric Units

Burner Cat. No.	Assy. No.	Total Input kW		Typical Blower Cat. No.†	Dimensions In Millimeters						Cross Sect. Area Sq. Cm.	Check Valve Pipe Style*	Approx. Ship Wt. Kgs.
		769 kW/M	962 kW/M		A	B	C	D	E	F			
240 TAH-R	109449	703	879	65-84S-1/3	308	313	152	479	241	2"	1484	A	55
280 TAH-R	109450	821	1026	65-84S-1/2	308	313	305	632	251	2"	1736	C	63
320 TAH-R	109451	938	1172	66-94S-3/4	308	313	305	784	251	2"	1981	C	72
360 TAH-R	109452	1055	1319	66-94S-3/4	308	478	305	937	251	2"	2226	C	81
400 TAH-R	109453	1172	1466	66-94S-3/4	613	478	305	479	251	2"	2471	D	91
440 TAH-R	109454	1290	1612	66-94S-3/4	613	478	305	632	267	3"	2723	C	99
480 TAH-R	109455	1407	1759	67-115S-1-1/2	613	478	305	784	267	3"	2968	C	110
520 TAH-R	109456	1524	1905	67-115S-1-1/2	613	478	457	937	267	3"	3213	C	124
560 TAH-R	109457	1641	2052	67-115S-2	918	478	457	479	267	3"	3458	D	139
600 TAH-R	109458	1759	2198	67-115S-2	918	478	457	632	267	3"	3710	C	154
640 TAH-R	109459	1876	2345	67-115S-2	918	478	457	784	267	3"	3955	C	161
680 TAH-R	109460	1993	2491	78-126S-3	918	478	457	937	267	3"	4200	C	172
720 TAH-R	109461	2110	2638	78-126S-3	918	478	457	1089	267	3"	4445	C	184

\* See page 2 for check valve piping styles.

† Blowers listed are satisfactory for duct pressures from -0.5" w.c. to +0.2" w.c. (-1.2 mbar to +0.5 mbar). For other conditions, see Data 140-5 for blower details and sizing.



**ECLIPSE COMBUSTION**

# Air Inlet Dimensions

240 TAH-R

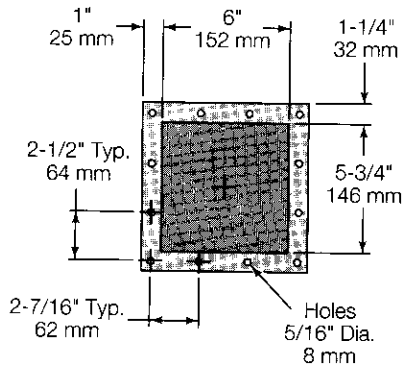

280 thru 480 TAH-R

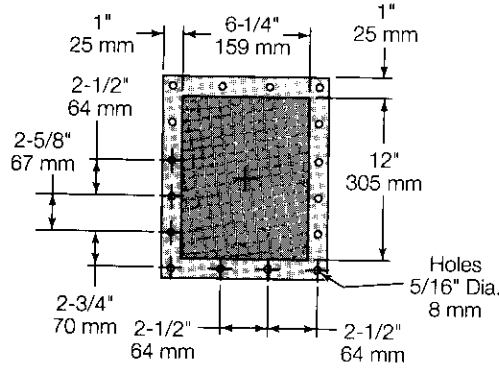

520 thru 720 TAH-R

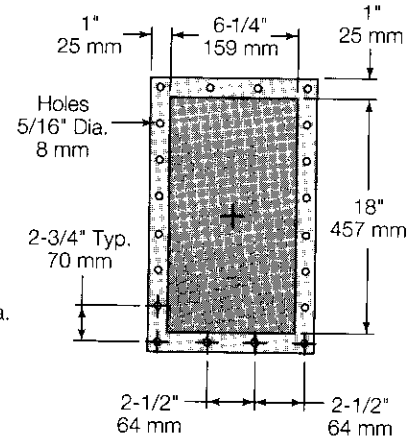

# Pilot Components & Dimensions

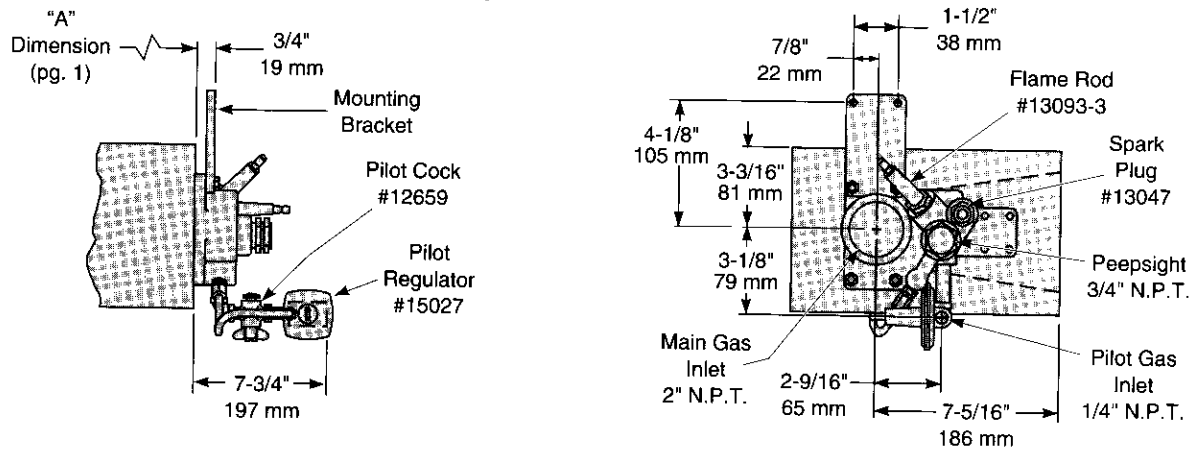

# Check Valve Pipe Styles

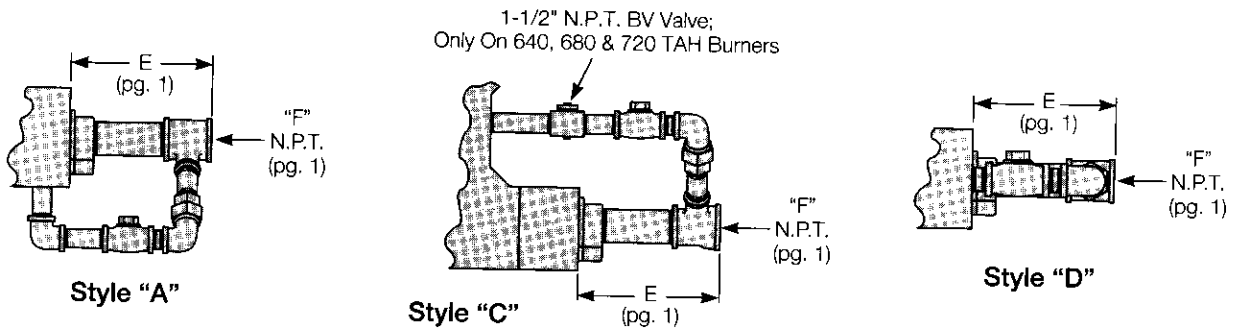

# Check Valve Assembly No.

Burner	Assy.	N.P.T.
240 TAH-R	550096	1"
280 thru 400 TAH-R	550100	1-1/4"
440 thru 720 TAH-R	550104	1-1/2"



**Offered By:**

Power Equipment Company  
2011 Williamsburg Road  
Richmond, Virginia 23231  
Phone (804) 236-3800  
Fax (804) 236-3882

---

[www.peconet.com](http://www.peconet.com)